

## Controller and Mini-programmer



Quick Guide -Code: FK48ENG09

Ascon Tecnolog S.r.l

Via Indipendenza, 56  
27029 Vigevano (PV) - ITALY  
Tel.: +39 0381 69871  
FAX: +39 0381 698730  
http://www.ascontecnologic.com  
info@ascontecnologic.com

### 1 - OUTLINE DIMENSIONS (mm)

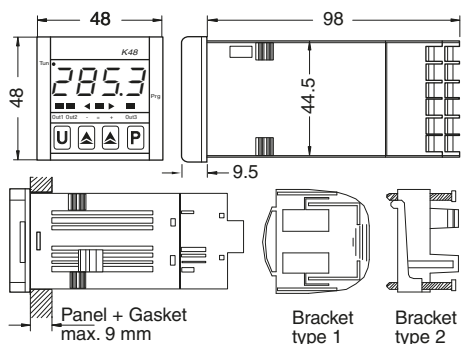

### 2 - CONNECTION DIAGRAM

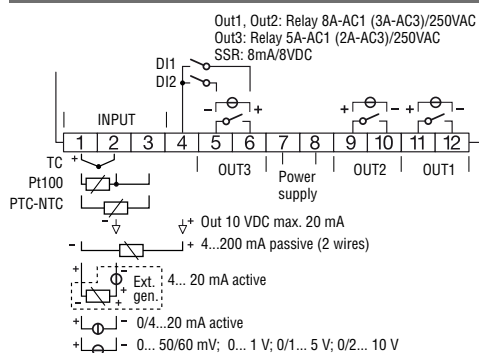

**Note:** The complete manual is available, free of charge, at: [www.ascontecnologic.com](http://www.ascontecnologic.com)

### 2.1 Mounting requirements

This instrument is intended for permanent installation, for indoor use only, in an electrical panel which encloses the rear housing, exposed terminals and wiring on the back. Select a mounting location having the following characteristics:

1. It should be easily accessible;
2. There is minimum vibrations and no impact;
3. There are no corrosive gases;
4. There are no water or other fluid (condensation);
5. The ambient temperature is in accordance with the operative temperature (0... 50°C);
6. The relative humidity is in accordance with the instrument specifications (20... 85%).

The instrument can be mounted on panel with a maximum thickness of 15 mm. When the maximum front protection (IP65) is desired, the optional gasket must be mounted.

### 2.2 General notes about wiring

1. Do not run input wires together with power cables;
2. External components (like zener barriers, etc.) connected between sensor and input terminals may cause errors in measurement due to excessive and/or not balanced line resistance or possible leakage currents;
3. When a shielded cable is used, it should be connected at one point only;
4. Pay attention to the line resistance; a high line resistance may cause measurement errors;
5. To avoid electrical shock, connect power at last;
6. For supply connections use No. 16 AWG or larger wires rated for at last 75°C;
7. Use copper conductors only;
8. Before connecting the instrument to the power line, make sure that line voltage is equal to the voltage shown on the identification label.
9. The power supply input is NOT fuse protected. Please, provide a T type 1A, 250 V fuse externally.

### 3 - CONFIGURATION PROCEDURE

#### 3.1 How to enter the configuration mode

1. Push the **[P]** button for more than 3 seconds. The display will show alternately **0** and **PASS**;
2. Using **▲** and/or **▼** buttons set the programmed password.

#### Notes:

- a) The factory default password for configuration parameters is **30**.
- b) The parameter changes are protected by a time out. If no key is pressed for more than 10

seconds the instrument automatically returns back to the Standard display, the new value of the last selected parameter will be lost and the parameter modification procedure closed. Sometimes can be useful to enter the parameter configuration procedure with no timeout (e.g. for the first time an instrument is configured). In this case, use a password equal to the previously set password + 1000 digits (e.g. 1000 + 30 [default] = 1030). It is always possible to manually end the parameter configuration procedure (see the next paragraph).

- c) During parameter modification the instrument continues performing the control. In certain conditions, when a configuration change can produce a heavy bump to the process, it is advisable to temporarily stop the control procedure during the programming procedure (the control output will be OFF). In this case use a password equal to the previously set password + 2000 digits (e.g. 2000 + 30 [default] = 2030). The control procedure will automatically restart when the configuration procedure will be manually closed.

3. Push the **[P]** button. If the password is correct the display will show the acronym of the first parameter group preceded by the symbol **↵**. In other words the display will show **↵ 100P**. The instrument is in configuration mode.

#### 3.2 How to exit the configuration mode

Push **[U]** button for more than 5 seconds. The instrument will come back to the "standard display".

#### 3.3 Keyboard functions during parameters modification

- [U]** A short press allows to exit the current parameter group and select a new parameter group. A long press allows to close the configuration parameter procedure (the instrument returns to the "standard display").
- [P]** When the display is showing a group, the key allows to enter in the selected group. When the display is showing a parameter, the key allows to store the value shown and go to the next parameter within the same group.

- ▲** Increases the value of the selected parameter.
  - ▼** Decreases the value of the selected parameter.
- Note:** The group selection is cyclic as well as the selection of the parameters in a group.

#### 3.4 Factory reset - Default parameters loading procedure

Sometimes, e.g. when you reconfigure an instrument previously used for other works or from other people or when you have made too many errors during configuration and you decided to reconfigure the instrument, it is possible to restore the factory configuration. This action allows you to put the instrument in a defined condition (in the same condition it was at the first Power ON).

The default data are the typical values loaded in the instrument prior to shipping from factory. To load the factory default parameter set, proceed as follows:

1. Press the **[P]** button for more than 5 seconds;
2. The display will show alternately **"PASS"** and **"0"**;
3. Using **▲** and **▼** buttons, set the value -481;
4. Push **[P]** button;
5. The instrument will turn OFF all LEDs then it will show **"OFFLINE"** messages and then it turn ON all LEDs of the display for 2 seconds and then it will restart as at the first power ON.

The procedure is complete.

### 4 - OPERATIVE MODES

#### 4.1 Keyboard function when the instrument is in Auto mode

- [U]** Performs the action programmed by [116] **u5r-b** (**[U]** button function during RUN TIME) parameter.
- [P]** Enters the parameter modification procedures.
- ▲** Starts the "Direct set point modification" function (see below).
- ▼** Displays the "Additional information" (see below).

#### 4.2 Direct set point modification

This function allows to modify rapidly the set point value selected by [79] **SPAL** or to the set point of the segment group currently in progress. The instrument is showing the "standard display".

1. Push **▼** button. The display will show alternately the acronym of the selected set point (e.g. SP2) and its value.

**Note:** When the programmer is running, the instrument will show the set point of the group currently in use.

2. By **▲** and **▼** buttons, assign to this parameter the desired value.
3. Do not push any button for more than 5 second or push the **[P]** button. In both cases the instrument memorize the new value and come back to the "standard display".

**Note:** If the selected set point has not been promoted to the Operator level, the instrument allows you to see the value but not to modify it.

#### 4.3 Additional information

This instrument is able to show you some additional information that can help you to manage your system.

1. When the instrument is showing the "standard display" push **▲** button. The display will show **"H"** or **"c"** followed by a number. This value is the current

power output applied to the process. **"H"** means Heating action while **"c"** means Cooling action.

2. Push **▲** button again. When the programmer is running the instrument will show the segment currently performed and the Event status as shown below:

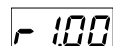

where the first figure can be **"r"** for a ramp or **"s"** for a soak, the next digit shows the number of the segment (ex. S3 indicates stasis 3) and the two Less Significant Digits show you the status of the two event (LSD is the Event 2).

3. Push **▲** button again. When the programmer is running the instrument will show the theoretical remaining time to the end of the program preceded by a **P** letter:

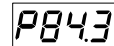

4. Push **▲** button again. When the wattmeter function is running the instrument will show **"U"** followed by the measured energy.

**Note:** The energy calculation will be in accordance with the [126] **UoL** parameter setting.

5. Push **▲** button again. When the "Worked time count" is running the instrument will show **"d"** for days or **"h"** for hours followed by the measured time.
6. Push **▲** button again. The instrument returns to the "standard display".

**Note:** The additional information visualization is subject to a time out of 10 seconds.

### 5 - ERROR MESSAGES

#### 5.1 Out of Range Signals

The display shows the OVER-RANGE and UNDER-RANGE conditions with the following indications:

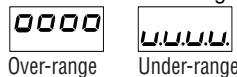

The sensor break will be signalled as an out of range:



**Note:** When an over-range or an under-range is detected, the alarms operate as in presence of the maximum or the minimum measurable value respectively.

To check the out of span Error condition, proceed as follows:

1. Check the signal source and the connecting line.

### WARNING

Whenever a failure or a malfunction of the device may cause dangerous situations for persons, things or animals, please remember that the plant must be equipped with additional devices which will guarantee safety.

### 4 - PARAMETERS TABLES

#### ↵ InP group (parameters relative to the inputs)

no.	Par.	Description	Range	Default	Vis. Promo.			
1	HcFG	It shows the current hardware	TC/RTD, TC/PTC, Current, Voltage	According to the HW	Not displayed			
2	SEnS	Sensor selection (according to the HW)						
		TC, Pt100 input	J, crAL, S, r, t, Ir.J, Ir.cA, Pt1, 0... 50 (mV), 0... 60 (mV), 12... 60 (mV)	J	A-4			
		TC, PTC, NTC input	J, crAL, S, r, t, Ir.J, Ir.cA, Ptc, ntc, 0... 50 (mV), 0... 60 (mV), 12... 60 (mV)	Ptc				
		I input	0... 20 (mA), 4... 20 (mA)	4.20				
V input	0... 5(V), 1... 5(V), 0... 10(V), 2... 10(V), 0... 1 (V)	0.10						
3	dP	Decimal figure	0... 3	0	A-5			
4	SSc	Initial scale readout	From -1999 to FSC (E.U.)	-1999	A-6			
5	FSc	Final scale readout	From SSC to 9999 (E.U.)	9999	A-7			
6	unit	Engineering unit	°C or °F	0 = °C	A-8			
7	FIL	Digital filter on the measured value	From 0 (OFF)... 20.0 (s)	1.0	C-0			
8	inE	Selection of the Sensor Out of Range type that will enable the safety output value	or = Over-range ur = Under-range our = Over and Under	our	C-0			
9	oPE	Safety output value	-100... 100 (%)	0	C-0			
10	diF1	Digital input 1 function	oFF = No function 1 = Alarm Reset 2 = Alarm acknowledge (ACK) 3 = Hold of the measured value 4 = Stand by mode 5 = HEAT with SP1 and Cool with "SP2" 6 = Timer run/hold/reset [transition] 7 = Timer run [transition] 8 = Timer reset [transition] 9 = Timer run/hold [Status] 10 = Program run 11 = Program reset 12 = Program hold 13 = Program run/hold 14 = Program run/reset 15 = Instrument in Manual mode 16 = Sequential set point selection 17 = SP1/SP2 selection 18 = Set point Binary selection 19 = Digital inputs in parallel to the UP and DOWN keys 20 = Timer RUN/Reset			nonE	A-13	
			11	diF2	Digital input 2 function	See diF1	nonE	A-14

#### ↵ Out Group (parameters relative to the outputs)

no.	Par.	Description	Range	Default	Vis. Promo.			
12	o1F	Out 1 function	NonE = Output not used H.rEG = Heating output c.rEG = Cooling output AL = Alarm output t.out = Timer output t.HoF = Timer out -OFF in hold P.End = Program end indicator P.HLd = Program hold indicator P.uit = Program wait indicator P.run = Program run indicator P.Et1 = Program Event 1 P.Et2 = Program Event 2 or.bo = Out-of-range or burn out indicator P.FAL = Power failure indicator bo.PF = Out-of-range, burn out and Power failure indicator diF.1 = DO repeats the DI1 status diF.2 = DO repeats the DI2 status St.by = Stand by status indicator on = Out 1 ever ON			H.reg	A-16	
			13	o1AL	Alarms linked up with out 1	0... 31 +1 = Alarm 1 +2 = Alarm 2 +4 = Alarm 3 +8 = Loop break alarm +16 = Sensor Break (burn out)	AL1	A-17

2. Make sure that the input signal is in accordance with the instrument configuration. Otherwise, modify the input configuration (see section 3).
3. If no error is detected, send the instrument to your supplier to be checked.

### 5.2 List of possible errors

**ErAT** Fast Auto-tune cannot start. The measure value is too close to the set point. Push the **[P]** button in order to delete the error message.

**NoAt** Auto-tune not finished within 12 hours.

**ErEP** Possible problem of the instrument memory. The message disappears automatically. If the error continues, send the instrument to the supplier.

### 6 - GENERAL NOTES

#### 6.1 Proper Use

Every possible use not described in the complete manual ([www.ascontecnologic.com](http://www.ascontecnologic.com)) must be considered as a improper use.

This instrument is in compliance with EN 61010-1 "Safety requirements for electrical equipment for measurement, control and laboratory use"; for this reason it could not be used as a safety equipment.

**Ascon Tecnolog S.r.l. and its legal representatives do not assume any responsibility for any damage to people, things or animals deriving from violation, wrong or improper use or in any case not in compliance with the instrument's features.**

#### 6.2 Warranty and repairs

This product is under warranty against manufacturing defects or faulty materials that are found within 12 months from delivery date.

The warranty is limited to repairs or to the replacement of the instrument.

The tampering of the instrument or an improper use of the product will bring about the immediate withdrawal of the warranty's effects.

In the event of a faulty instrument, either within the period of warranty, or further to its expiry, please contact our sales department to obtain authorisation for sending the instrument to our company.

The faulty product must be shipped to Ascon Tecnolog with a detailed description of the faults found, without any fees or charge for Ascon Tecnolog, except in the event of alternative agreements.

Before supplying tension to the instrument, make sure that it is perfectly dry.

no.	Par.	Description	Range	Default	Vis. Promo.
14	o1Ac	Out 1 action	dir = Direct action rEU = Reverse action dir.r = Direct with reversed LED ReU.r = Reverse with reversed LED	dir	C-0
15	o2F	Out 2 function	See: 12 - o1F: Out1 functions	AL	A-19
16	o2AL	Alarms linked up with the out 2	See: 13 - o1AL: Alarms linked up with out 1	+1 = AL1	A-20
17	o2Ac	Out 2 action	See: 14 - o1Ac: Out 1 action	dir	C-0
18	o3F	Out 3 function	See: 12 - o1F: Out1 functions	AL	A-22
19	o3AL	Alarms linked up with the out 3	See: 13 - o1AL: Alarms linked up with out 1	+2 = AL2	A-23
20	o3Ac	Out 3 action	See: 14 - o1Ac: Out 1 action	dir	C-0
21	o4F	Out 4 function	See: 12 - o1F: Out1 functions	AL	A-24
22	o4AL	Alarms linked up with the out 4	See: 13 - o1AL: Alarms linked up with out 1	+3 = AL3	A-25
23	o4Ac	Out 4 action	See: 14 - o1Ac: Out 1 action	dir	C-0

### AL1 Group (parameters relative to AL1 - alarm 1)

no.	Par.	Description	Range	Default	Vis. Promo.
24	AL1t	Alarm 1 type	nonE = Alarm not used LoAb = Absolute low alarm HiAb = Absolute high alarm LHAb = Absolute band alarm SE.br = Sensor Break LoE = Deviation low alarm (relative) HiE = Deviation high alarm (relative) LHdE = Relative band alarm	LoAb	A-47
25	Ab1	Alarm 1 function	0... 15 +1 = Not active at power ON +2 = Latched alarm (manual reset) +4 = Acknowledgeable alarm +8 = Relative alarm not active at set point change	0	C-0
26	AL1L	For High and low alarms, it is the low limit of the AL1 threshold For band alarm, it is low alarm threshold	From -1999 to AL1H (E.U.)	-1999	A-48
27	AL1H	For High and low alarms, it is the high limit of the AL1 threshold For band alarm, it is high alarm threshold	From AL1L to 9999 (E.U.)	9999	A-49
28	AL1	AL1 threshold	From AL1L to AL1H (E.U.)	0	A-50
29	HAL1	AL1 hysteresis	1... 9999 (E.U.)	1	A-51
30	AL1d	AL1 delay	From 0 (OFF) to 9999 (s)	oFF	C-0
31	AL1o	Alarm 1 enabling during Stand-by mode and out of range conditions	0 = Alarm 1 disabled during Stand-by and out of range 1 = Alarm 1 enabled in stand by mode 2 = Alarm 1 enabled in out of range condition 3 = Alarm 1 enabled in stand by mode and in overrange condition	0	C-0

### AL2 Group (parameters relative to AL2 - alarm 2)

no.	Par.	Description	Range	Default	Vis. Promo.
32	AL2t	Alarm 2 type	See: 24 - Ab1t: Alarm 1 Type	HiAb	A-54
33	Ab2	Alarm 2 function	See: 25 - AL1f: Alarm 1 function	0	C-0
34	AL2L	For High and low alarms, it is the low limit of the AL2 threshold For band alarm, it is low alarm threshold	See: 26 - AL1L	-1999	A-56
35	AL2H	For High and low alarms, it is the high limit of the AL2 threshold For band alarm, it is high alarm threshold	See: 27 - AL1H	9999	A-57
36	AL2	AL2 threshold	See: 28 - AL1: Alarm 1 threshold	0	A-58
37	HAL2	AL2 hysteresis	See: 29 - HAL1: Alarm 1 hysteresis	1	A-59
38	AL2d	AL2 delay	See: 30 - AL1d: AL1 delay	oFF	C-0
39	AL2o	Alarm 2 enabling during Stand-by mode and out of range conditions	See: 31 - AL1o: Alarm 1 enabling during Stand-by mode and out of range conditions	0	C-0

### AL3 Group (parameters relative to AL3 - alarm 3)

no.	Par.	Description	Range	Default	Vis. Promo.
40	AL3t	Alarm 3 type	See: 24 - Ab1t: Alarm 1 Type	nonE	C-0
41	Ab3	Alarm 3 function	See: 25 - AL1f: Alarm 1 function	0	C-0
42	AL3L	For High and low alarms, it is the low limit of the AL3 threshold For band alarm, it is low alarm threshold	See: 26 - AL1L	-1999	C-0
43	AL3H	For High and low alarms, it is the high limit of the AL3 threshold For band alarm, it is high alarm threshold	See: 27 - AL1H	9999	C-0
44	AL3	AL3 threshold	See: 28 - AL1: Alarm 1 threshold	0	C-0
45	HAL3	AL3 hysteresis	See: 29 - HAL1: Alarm 1 hysteresis	1	C-0
46	AL3d	AL3 delay	See: 30 - AL1d: AL1 delay	oFF	C-0
47	AL3o	Alarm 3 enabling during Stand-by mode and out of range conditions	See: 31 - AL1o: Alarm 1 enabling during Stand-by mode and out of range conditions	0	C-0

### LBA Group

no.	Par.	Description	Range	Default	Vis. Promo.
48	LbAt	LBA time	From 0 (oFF) to 9999 (s)	oFF	C-0
49	LbSt	Δ measure for LBA during Soft start	From 0 (oFF) to 9999 (E.U.)	10	C-0
50	LbAS	Δ measure for LBA	1... 9999 (E.U.)	20	C-0
51	LbCA	Condition for LBA enabling	uP = Active when Pout = 100% dn = Active when Pout = -100% both = Active in both cases	both	C-0

### REG Group

no.	Par.	Description	Range	Default	Vis. Promo.
52	cont	Control type	Pid = PID (heat and/or) On.FA = ON/OFF asymmetric hysteresis On.FS = ON/OFF symmetric hysteresis nr = Heat/Cool ON/OFF control with neutral zone	Pid	A-25
53	Auto	Autotuning selection	-4 = Oscillating auto-tune with automatic restart at power ON and after all point change -3 = Oscillating auto-tune with manual start -2 = Oscillating tune with automatic start at first power ON only -1 = Oscillating autotune with auto restart at each power ON 0 = Not used 1 = Fast auto tuning with auto restart at each power ON 2 = Fast auto-tune with auto start at first power ON only 3 = FAST auto-tune with manual start 4 = FAST auto-tune with automatic restart at power ON and after a set point change	2	C-0
54	Aut.r	Manual start of the Autotuning	oFF = Not active on = Active	oFF	A-26
55	SELF	Self tuning enabling	YES = The instrument do not perform the self-tuning no = The instrument is performing the self-tuning	no	C-0
56	HSEt	Hysteresis of the ON/OFF control	0... 9999 (E.U.)	1	A-27
57	cPdt	Time for compressor protection	From 0 (oFF) to 9999 (s)	oFF	C-0
58	Pb	Proportional band	0... 9999 (E.U.)	50	A-28
59	int	Integral time	From 0 (oFF) to 9999 (s)	200	A-29
60	dEr	Derivative time	From 0 (oFF) to 9999 (s)	50	A-30
61	Fuoc	Fuzzy overshoot control	0.00... 2.00	0.50	A-31
62	H.Act	Heating output actuator	SSr = SSR rELy = Relay SLOu = Slow actuators	SSr	A-32
63	trcH	Heating output cycle time	0.1... 130.0 (s)	20.0	C-0
64	PrAt	Power ratio between heating and cooling action	0.01... 99.99	1.00	A-34
65	c.Act	Cooling output actuator	SSr = SSR rELy = Relay SLOu = Slow actuators	SSr	A-35
66	trcC	Cooling output cycle time	0.1... 130.0 (s)	20.0	C-0
67	rS	Manual reset (Integral pre-load)	-100.0... +100.0 (%)	0.0	C-0
68	od	Delay at power ON	From 0.00 (oFF) to 99.59 (hh.mm)	oFF	C-0
69	St.P	Maximum power output used during soft start	-100... 100 (%)	0	C-0
70	SSt	Soft start time	From 0.00 (oFF) to 8.00 (inF)(hh.mm)	oFF	C-0
71	SSIH	Threshold for soft start disabling	-1999... +9999 (E.U.)	9999	C-0

### SP Group

no.	Par.	Description	Range	Default	Vis. Promo.
72	nSP	Number of used set points	1... 4	1	A-38
73	SPLL	Minimum set point value	From -1999 to SPHL	-1999	A-39
74	SPHL	Maximum set point value	From SPLL to 9999	9999	A-40
75	SP 1	Set point 1	From SPLL to SPLH	0	O-41
76	SP 2	Set point 2	From SPLL to SPLH	0	O-42
77	SP 3	Set point 3	From SPLL to SPLH	0	O-43
78	SP 4	Set point 4	From SPLL to SPLH	0	O-44
79	SPAt	Selection of the active set point	From 1 (SP 1) to nSP	1	O-45

no.	Par.	Description	Range	Default	Vis. Promo.
80	SP.r	Remote set point type	RSP = The value coming from serial link is used as remote set point trin = The value will be added to the local set point selected by SPAt and the sum becomes the operative set point PErc = The value will be scaled on the input range and this value will be used as remote set point	trin	C-0
81	SP.Lr	Local/remote set point selection	Loc = local rEn = remote	Loc	C-0
82	SP.u	Rate of rise for POSITIVE set point change	0.01... 100.00 (inF) Eng. units per minute	inF	C-0
83	SP.d	Rate of rise for NEGATIVE set point change	0.01... 100.00 (inF) Eng. units per minute	inF	C-0

### Tin Group

no.	Par.	Description	Range	Default	Vis. Promo.
84	tr.F	Independent timer function	nonE = Timer not used i.d.A = Delayed start timer i.u.P.d = Delayed start at power up i.d.d = Feed-through timer i.P.L = Asymmetrical oscillator, start OFF i.L.P = Asymmetrical oscillator, start ON	nonE	A-62
85	tr.u	Timer unit	hh.nn = Hours and minutes nn.SS = Minutes and seconds SSS.d = Second and tenth of seconds	nn.SS	A-63
86	tr.t1	Time 1	When tr.u < 20: 0.01... 99.59 When tr.u = 200: 0.1... 995.9	1.00	A-64
87	tr.t2	Time 2	When tr.u < 2: 00.00 (oFF)... 99.59 (inF) When tr.u = 2: 000.0 (oFF)... 995.9 (inF)	1.00	A-65
88	tr.St	Timer status	rES = Timer reset run = Timer run HoLd = Timer hold	rES	C-0

### Prg Group

no.	Par.	Description	Range	Default	Vis. Promo.
89	Pr.F	Program action at power ON	nonE = Programmer not used S.u.P.d = Start at power ON with a first step in stand-by S.u.P.S = Start at power ON u.d.i.G = Start at Run command detection only u.d.G.d = Start at Run command with a first step in stand-by	nonE	A-67
90	Pr.u	Engineering unit of the soak	hh.nn = Hours and minutes nn.SS = Minutes and seconds	hh.nn	A-68
91	Pr.E	Instrument behaviour at the end of the program execution	cnt = Continue SPAt = Go to the set point selected by SPAt St.by = Go to stand-by mode	SPAt	A-71
92	Pr.Et	Time of the end program indication	From 0.00 (oFF) to 100.00 (inF) minutes and seconds	oFF	A-72
93	Pr.S1	Set point of the first soak	From SPLL to SPHL	0	A-73
94	Pr.G1	Gradient of the first ramp	0.1... 1000.0 (inF= Step transfer) Engineering Unit/minute	inF	A-74
95	Pr.t1	Time of the first soak	0.00... 99.59	0.10	A-75
96	Pr.b1	Wait band of the first soak	From 0 (oFF) to 9999 (E.U.)	oFF	A-76
97	Pr.E1	Events of the first group	00.00... 11.11	00.00	C-0
98	Pr.S2	Set point of the second soak	OFF or from SPLL to SPHL	0	A-78
99	Pr.G2	Gradient of the second ramp	0.1... 1000.0 (inF= Step transfer) Engineering Unit/minute	inF	A-79
100	Pr.t2	Time of the second soak	0.00... 99.59	0.10	A-80
101	Pr.b2	Wait band of the second soak	From 0 (oFF) to 9999 (E.U.)	oFF	A-81
102	Pr.E2	Events of the second group	00.00... 11.11	00.00	C-0
103	Pr.S3	Set point of the third soak	OFF or from SPLL to SPHL	0	A-83
104	Pr.G3	Gradient of the third ramp	0.1... 1000.0 (inF= Step transfer) Engineering Unit/minute	inF	A-84
105	Pr.t3	Time of the third soak	0.00... 99.59	0.10	A-85
106	Pr.b3	Wait band of the third soak	From 0 (oFF) to 9999 (E.U.)	oFF	A-86
107	Pr.E3	Events of the third group	00.00... 11.11	00.00	C-0
108	Pr.S4	Set point of the fourth soak	OFF or from SPLL to SPHL	0	A-88
109	Pr.G4	Gradient of the fourth ramp	0.1... 1000.0 (inF= Step transfer) Engineering Unit/minute	inF	A-89
110	Pr.t4	Time of the fourth soak	0.00... 99.59	0.10	A-90
111	Pr.b4	Wait band of the fourth soak	From 0 (oFF) 9999 (E.U.)	oFF	A-91
112	Pr.E4	Events of the fourth group	00.00... 11.11	00.00	C-0
113	Pr.St	Program status	rES = Program reset run = Program start HoLd = Program hold	0	C-0

### PAN Group

no.	Par.	Description	Range	Default	Vis. Promo.
114	PAS2	Password level 2	From 0 (oFF) to 999	20	A-93
115	PAS3	Password level 3	1... 999	30	C-0
116	uSrb	button function during run time	nonE = Not used tunE = Starts auto tuning functions oPLo = Manual mode (OPLo) AAc = Alarm reset ASi = Alarm acknowledge chSP = Sequential set point selection St.by = Stand-by mode Str.t = Run/hold/reset timer P.run = Program start Pr.ES = program reset Pr.H.r = Run/hold/reset program	nonE	A-94
117	diSP	Display management	nonE = Standard display Pou = Power output SPF = Final set point Spo = Operative set point AL1 = Alarm 1 threshold AL2 = Alarm 2 threshold AL3 = Alarm 3 threshold Pr.tu = Program time up Pr.td = Program time down P.t.tu = Program total time up P.t.td = Program total time down ti.uP = Timer time up ti.du = Timer time down Perc = Percent of the power output during soft start		A-95
118	AdE	Bargraph deviation	From 0 (oFF) to 9999	2	A-96
119	FILd	Filter on the displayed value	From 0.0 (oFF) to 20.0	oFF	C-0
120	dSPu	Status of the instrument at power up	AS.Pr = Starts as it was prior to the power down Auto = Starts in Auto mode oP.O = Starts in manual mode with a power output = 0 St.bY = Starts in stand-by mode	AS.Pr	C-0
121	oPr.E	Operative mode enabling	ALL = All Au.oP = Autp or manual (oPLo) only Au.Sb = Auto and Stand by only	ALL	C-0
122	oPEr	Operative mode selection	Auto = Automatic oPLo = Manual St.by = Stand-by	Auto	O-1

### SER Group

no.	Par.	Description	Range	Default	Vis. Promo.
123	Add	Address	From 0 (oFF) to 254	1	C-0
124	bAud	Baud rate	1200 (bit/s) 2400 (bit/s) 9600 (bit/s) 19.2 (kbit/s) 38.4 (kbit/s)	9600	C-0
125	trSP	Selection of the value to be retransmitted (Master)	nonE = Not used rSP = Operative set point PErc = Current power output (%)	nonE	C-0

### con Group(Wattmeter)

no.	Par.	Description	Range	Default	Vis. Promo.
126	co.ty	Measurement type	0 = OFF = Not used 1 = Instantaneous (kW) 2 = Power consumption (kW/h) 3 = Energy used during program execution 4 = Total worked days with threshold 5 = Total worked hours with threshold	nonE	A-97
127	UoLt	Nominal load voltage	1... 999 (Volt)	230	A-98
128	cur	Nominal load current	1... 999 (A)	10	A-99
129	h.Job	Threshold of the worked hours/days	From 0(oFF) to 9999	oFF	A-100

### cal Group (user calibration)

no.	Par.	Description	Range	Default	Vis. Promo.
130	A.L.P	Adjust low Point	From -1999 to AH.P-10 (E.U.)	0	A-9
131	A.L.o	Adjust low Offset	-300... +300 (E.U.)	0	A-10
132	A.H.P	Adjust High Point	From A.L.P +10 to 9999 (E.U.)	9999	A-11
133	A.H.o	Adjust High Offset	-300... +300 (E.U.)	0	A-12